



# Characterizing Guidance in Visual Analysis

Davide Ceneda, Theresia Gschwandtner, Thorsten May, Silvia Miksch, Hans-Jörg Schulz, Marc Streit, Christian Tominski



# What is Guidance?

Problem

What is Guidance aiming to solve?

Solution

Which principal forms does Guidance take?

# What is Guidance in VA?

## The Short Answer

**Guidance** is a computer-assisted process that aims to actively resolve a knowledge gap encountered by users during an interactive VA session.

Based on [Smith and Mosier 1986] [Engels 1996] [Dix et al. 2004]

# Characterizing Knowledge Gap and Process

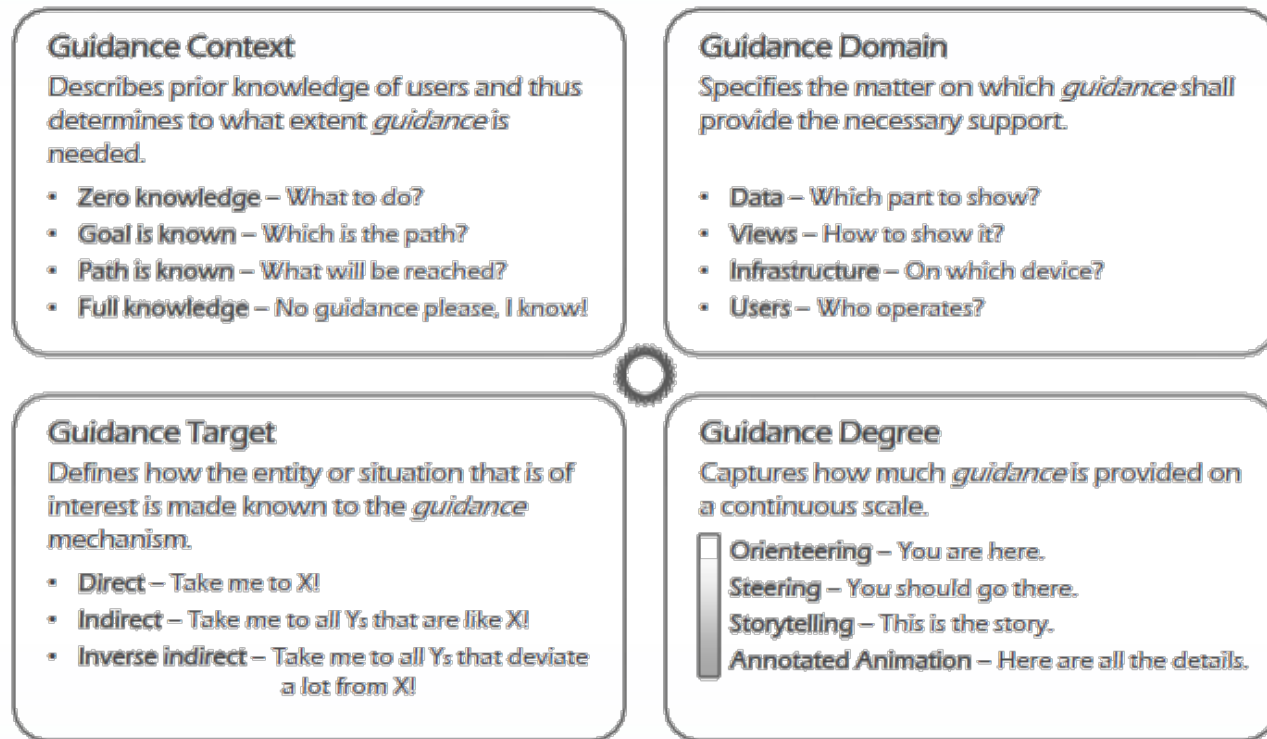

Towards a Characterization of Guidance in Visualization (Schulz et al. 2013)

REF	DG	Knowledge Deficit		Input			
		Path Unknown	Target Unknown	Domain	Data	Vis	User
		[X]	[X]	knowledge conventions workflow	raw meta-data topology	mapping visual artifact	interaction DOI
	Steering	X		X			
JGE12	Steering						
vdEW13	Orienteering						
			X		X		
GGL*14	Orienteering						
<b>90+ Papers</b>							
LSS*12	Orienteering						
AMST11	Orienteering						
MA14	Orienteering		X	X			
KNS	Orienteering	X?					X
		X?					X
DR00	Orienteering						

# The Knowledge Gap: Guidance Type

- **target unknown**
  - What's a desired result?
- **path unknown**
  - How to reach a desired result?
- **target and path unknown**
  - no goal, no direction, no nothing...

# The Knowledge Gap: Guidance Domain

- **Data – Where to look?**  
*Example: degree-of-interest functions*
- **Tasks – What to do?**  
*Example: analytic workflows*
- **VA Methods – How to do it?**  
*Example: recommender systems*
- **Infrastructure – Which hardware/software to use?**  
*Example: smart view management*
- **Users – Who should do it?**  
*Example: expert finding*

# The Computer-Assisted Process

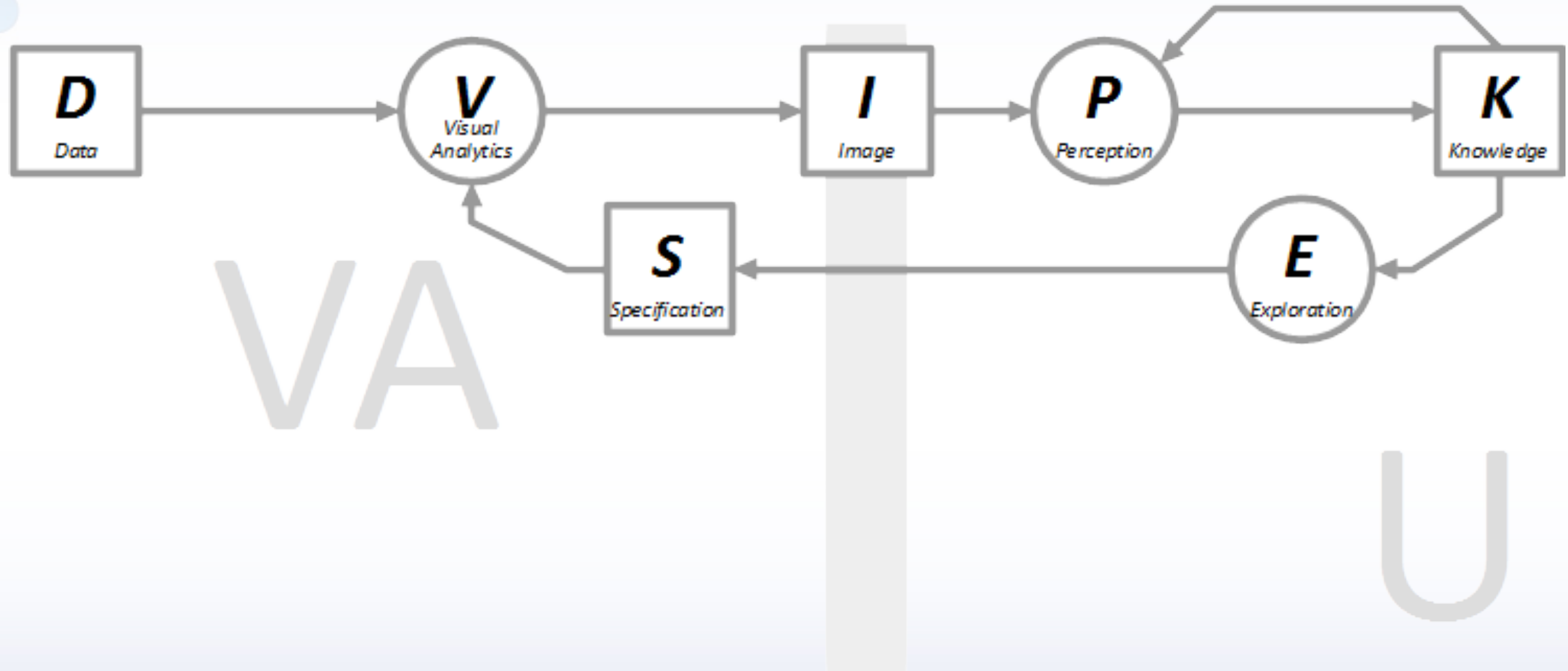

# The Computer-Assisted Process

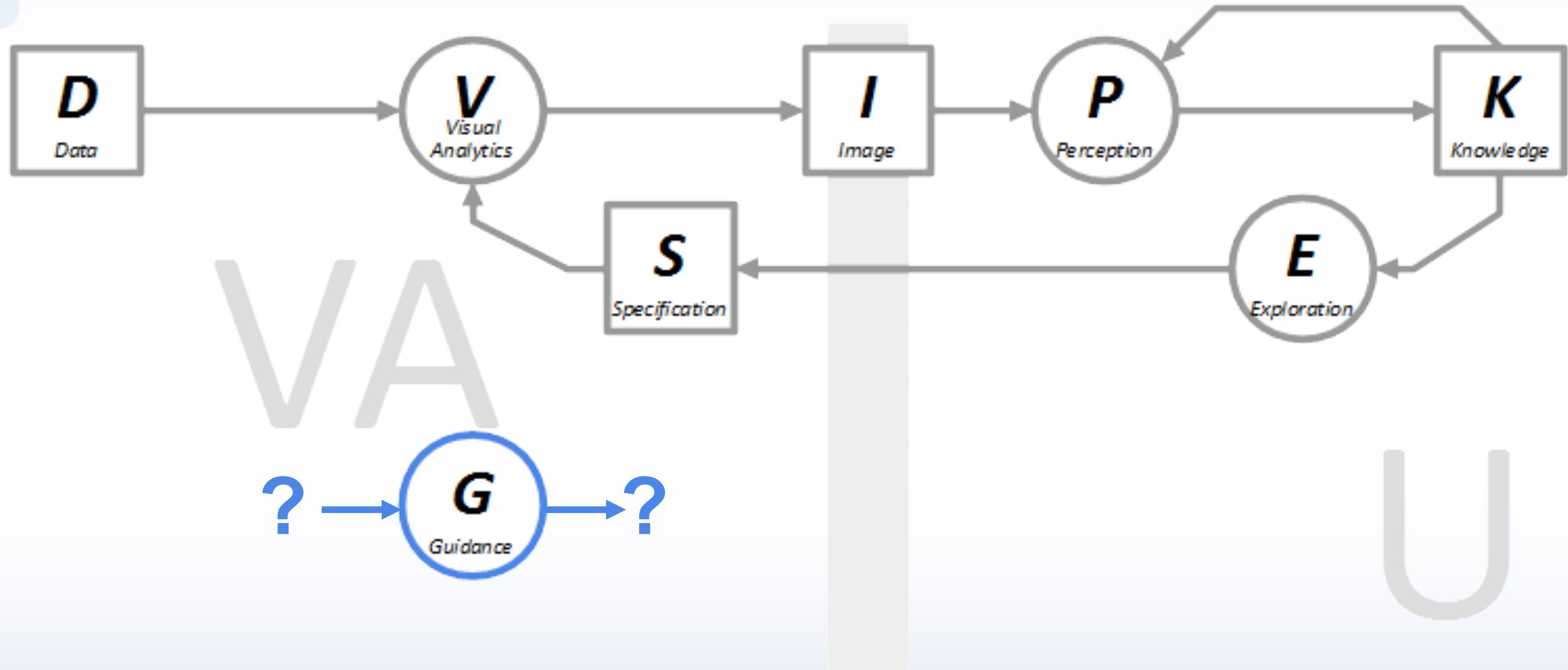



# The Computer-Assisted Process

## Guidance Inputs: The Data

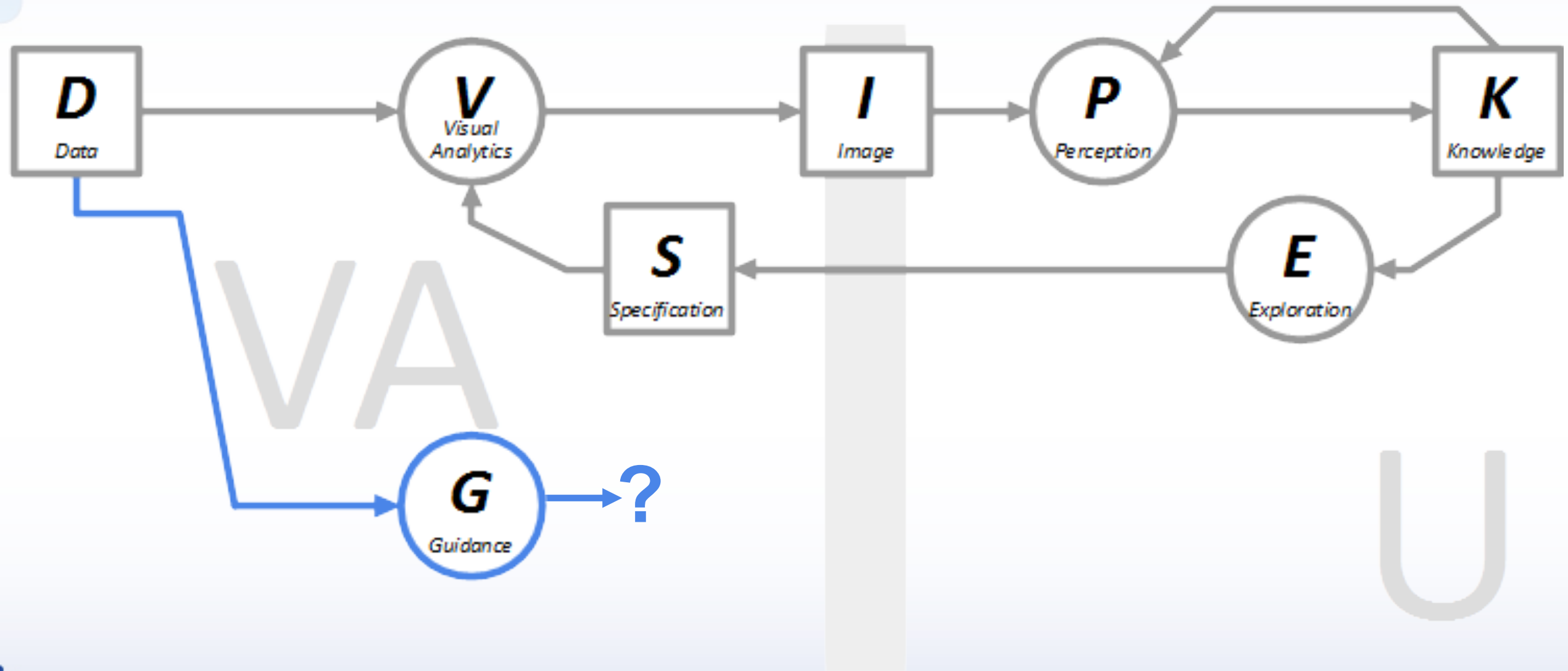

# The Computer-Assisted Process

## Guidance Inputs: The Visualization Image

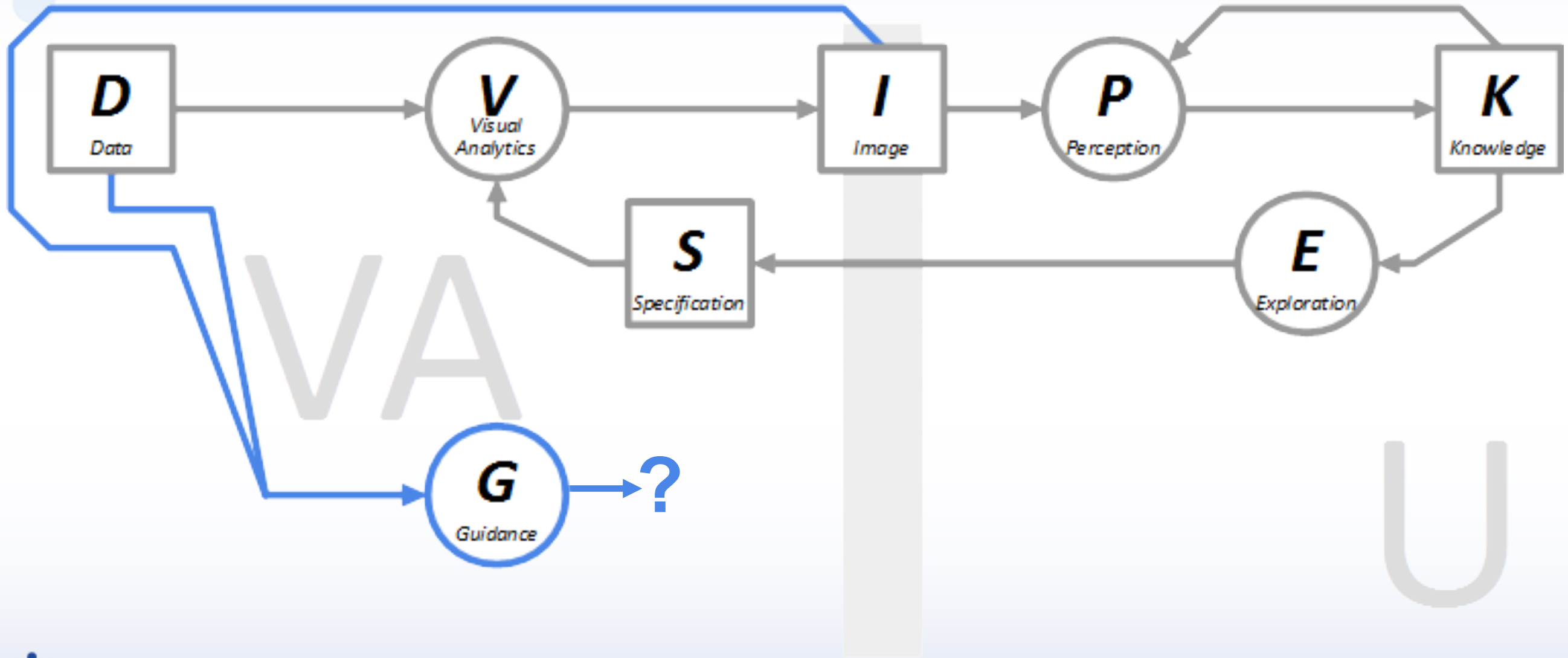

# The Computer-Assisted Process

## Guidance Inputs: The Interaction History

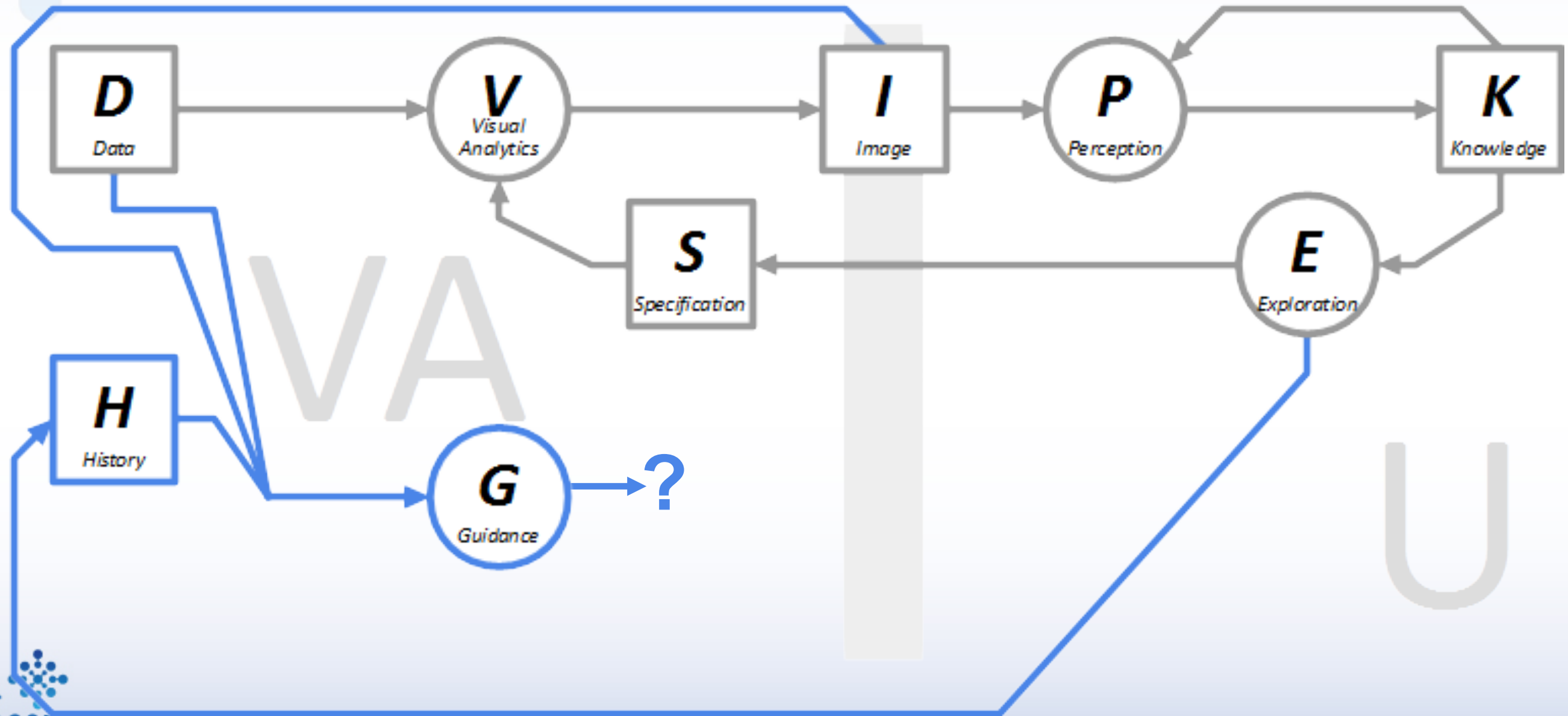

# The Computer-Assisted Process

## Guidance Inputs: The User Knowledge

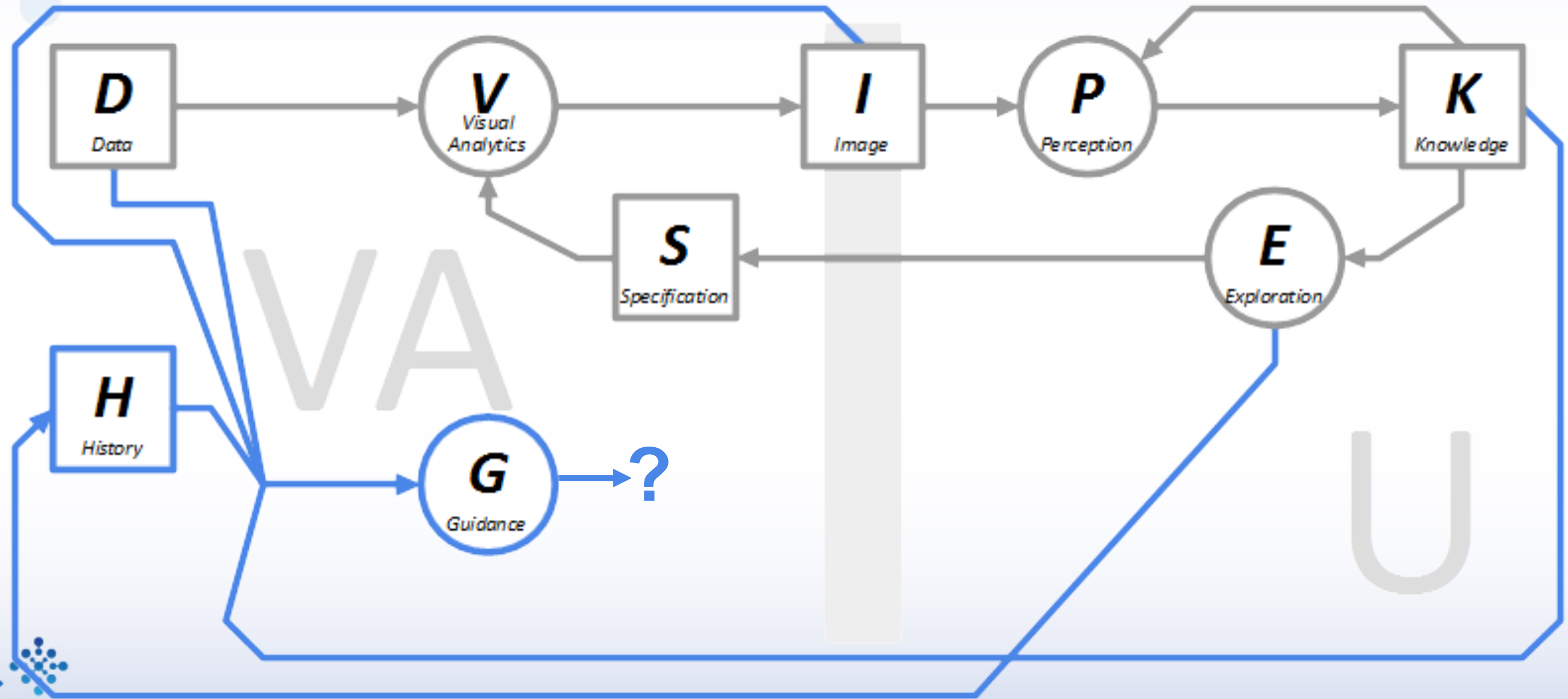

# The Computer-Assisted Process

## Guidance Inputs: The Domain Knowledge

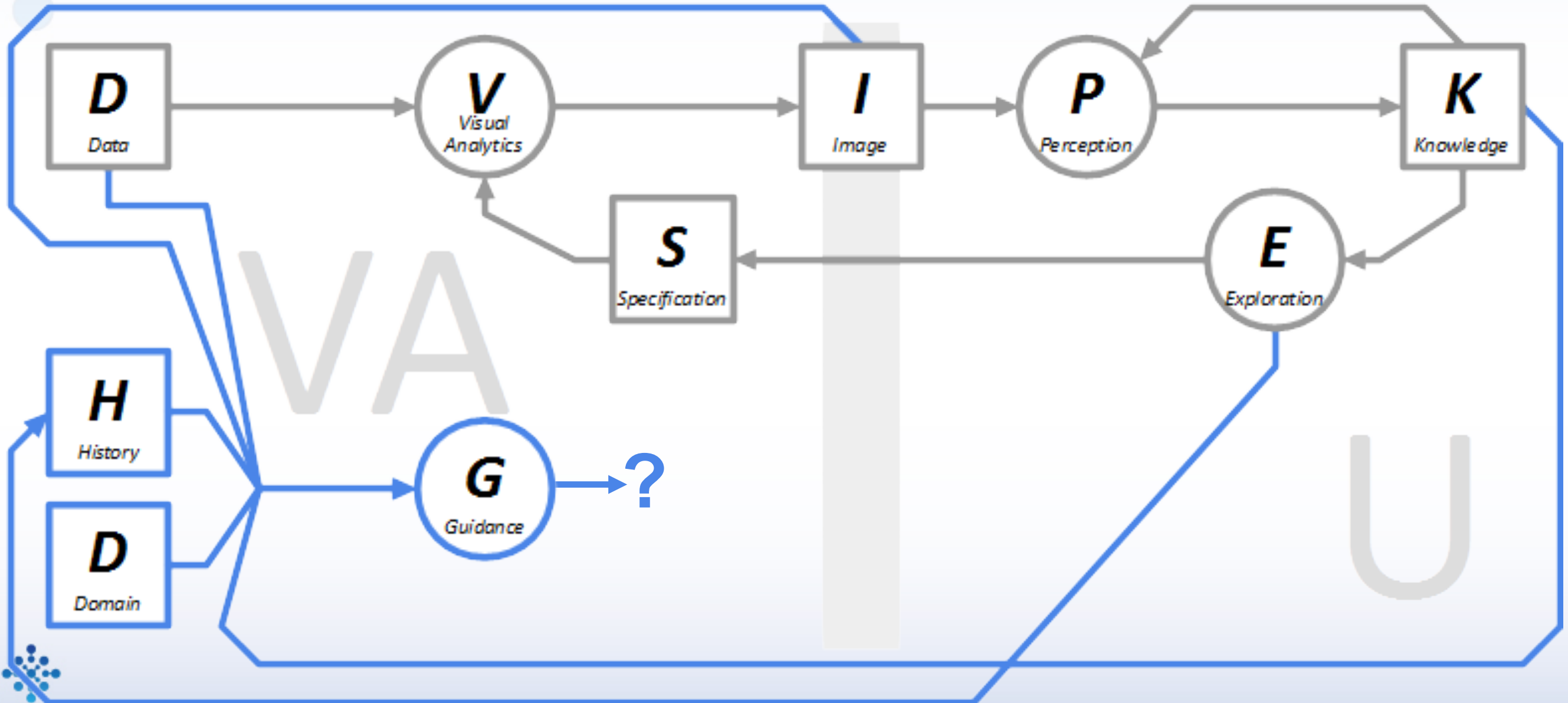

# The Computer-Assisted Process

## The Guidance Outputs: Cues in the Visualization

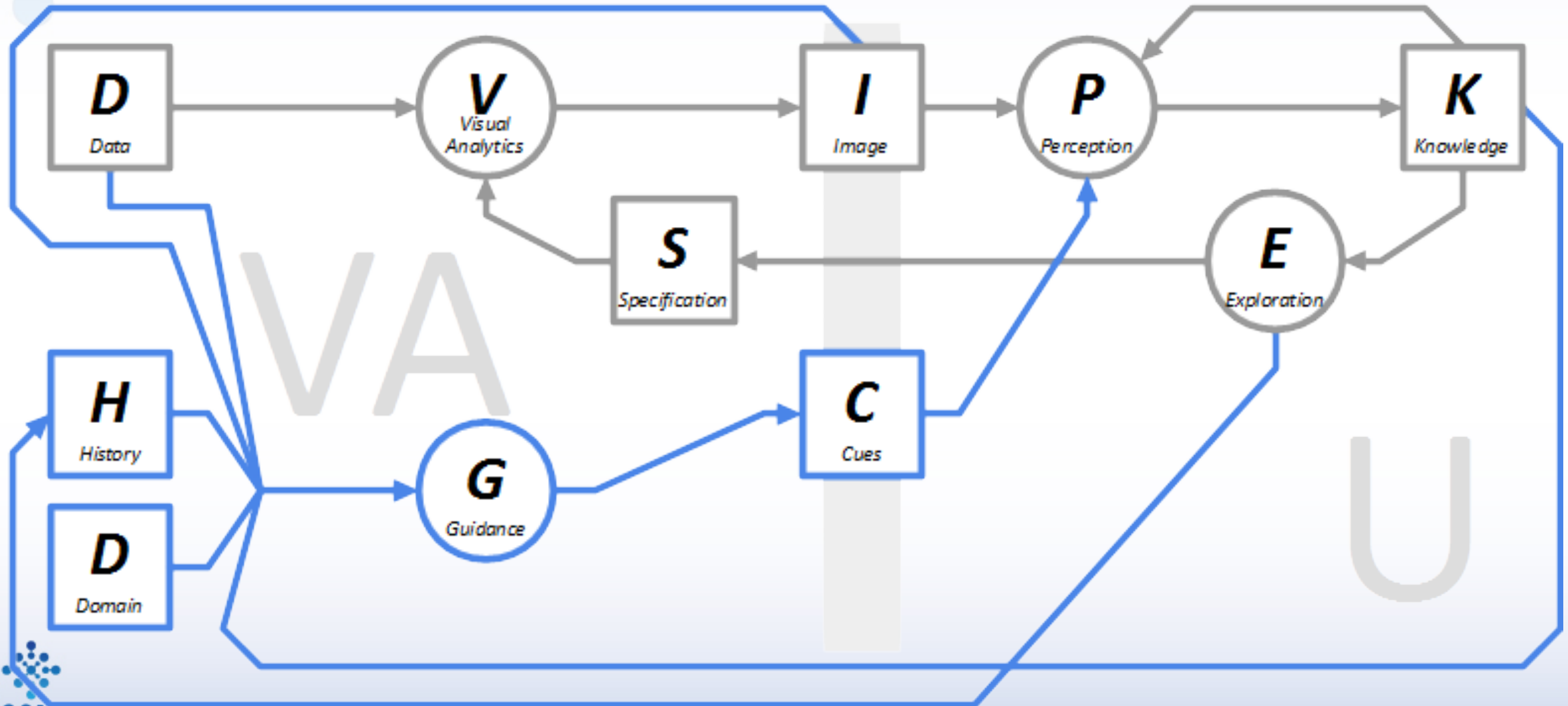



# The Computer-Assisted Process

## The Guidance Outputs: Cues in the Visualization

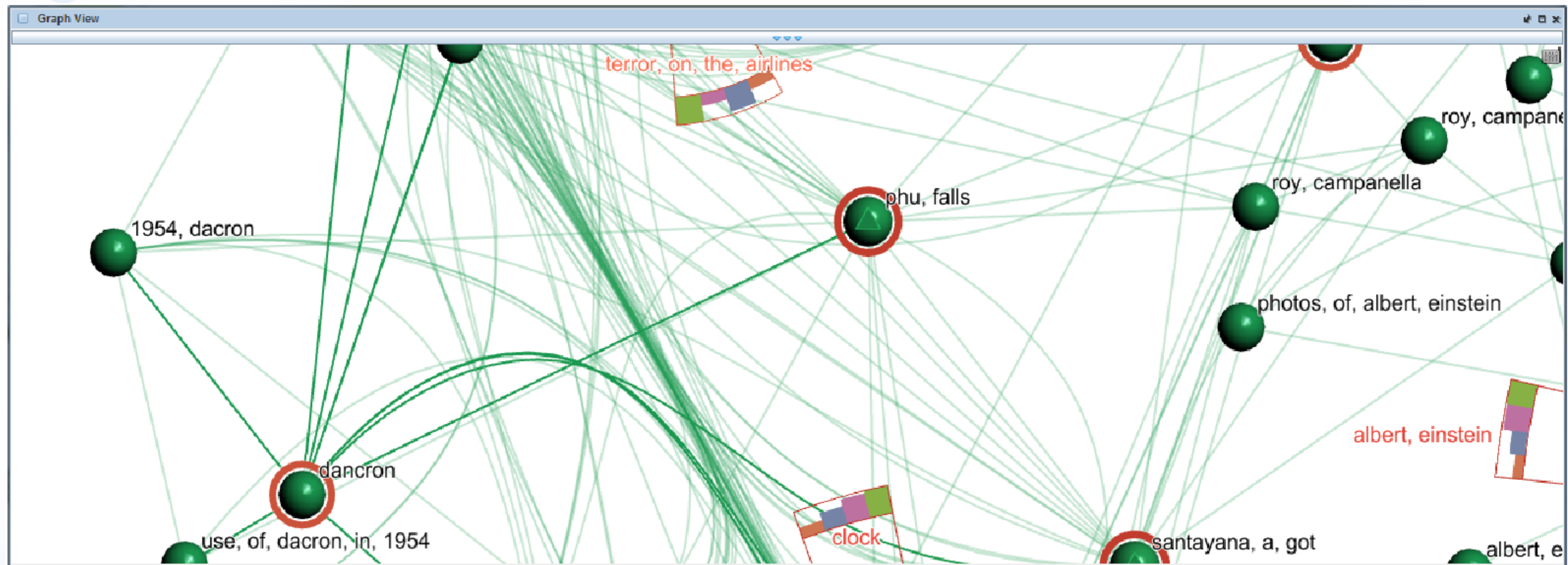

Navigation Recommendations [Gladisch et al. 2013]

# The Computer-Assisted Process

## The Guidance Outputs: Annotated Options in the UI

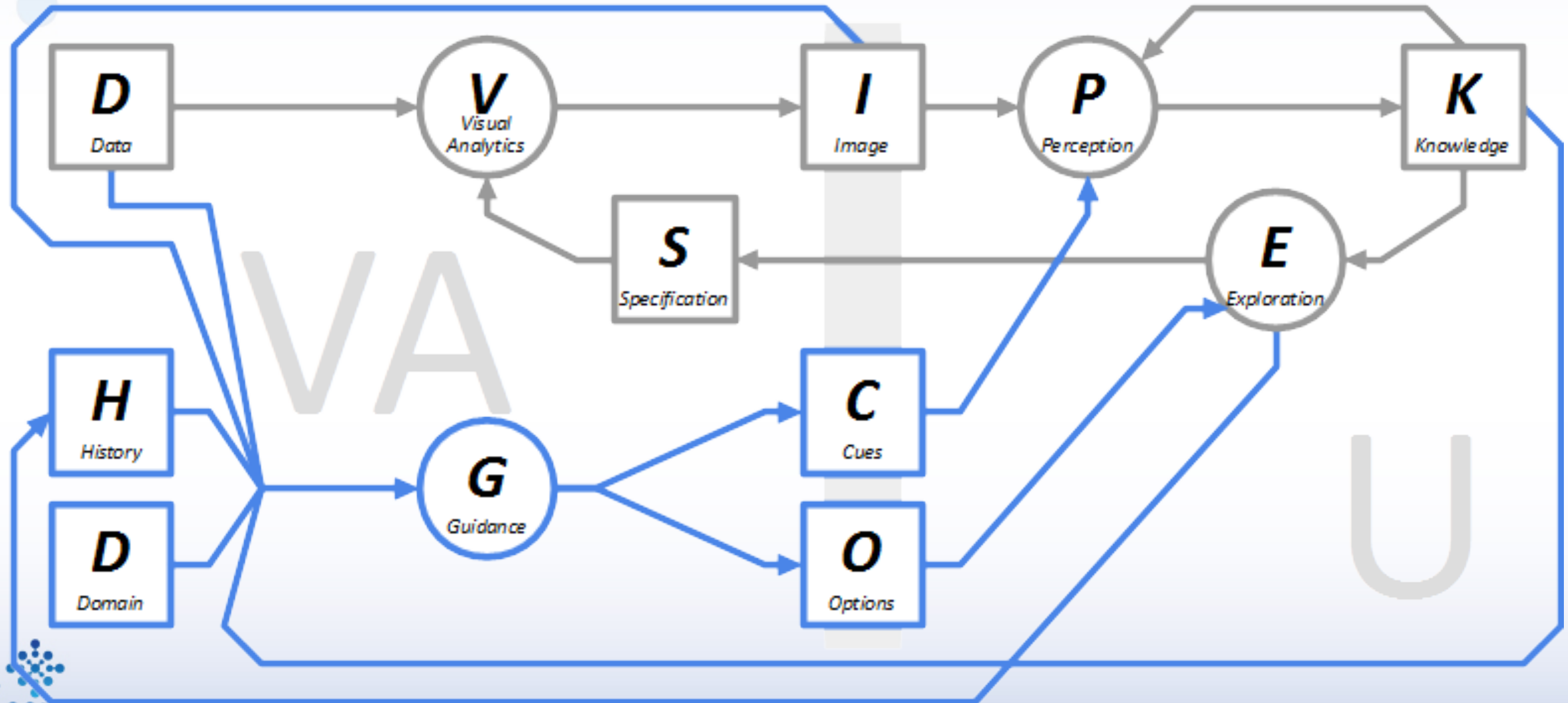



# The Computer-Assisted Process

## The Guidance Outputs: Annotated Options in the UI

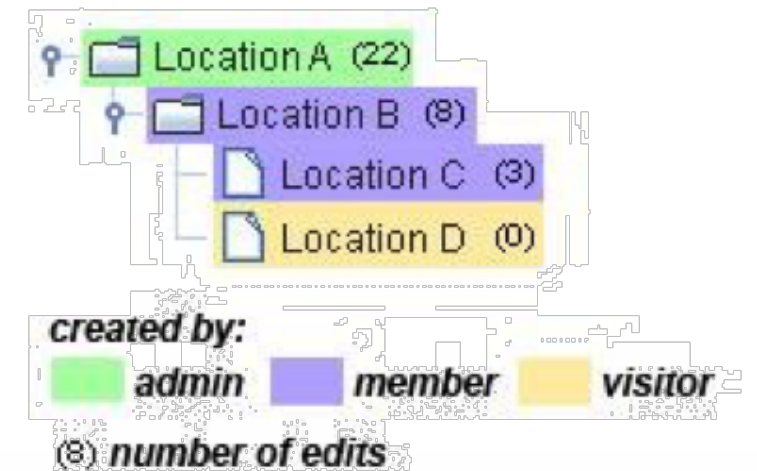
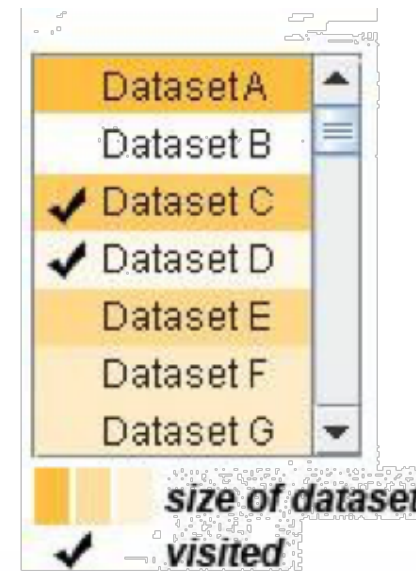
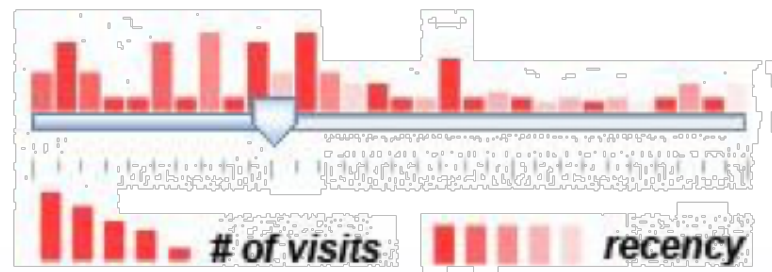

Scented Widgets [Willett et al. 2007]

# The Computer-Assisted Process

## The Guidance Degree: Orienting – Where can I go?

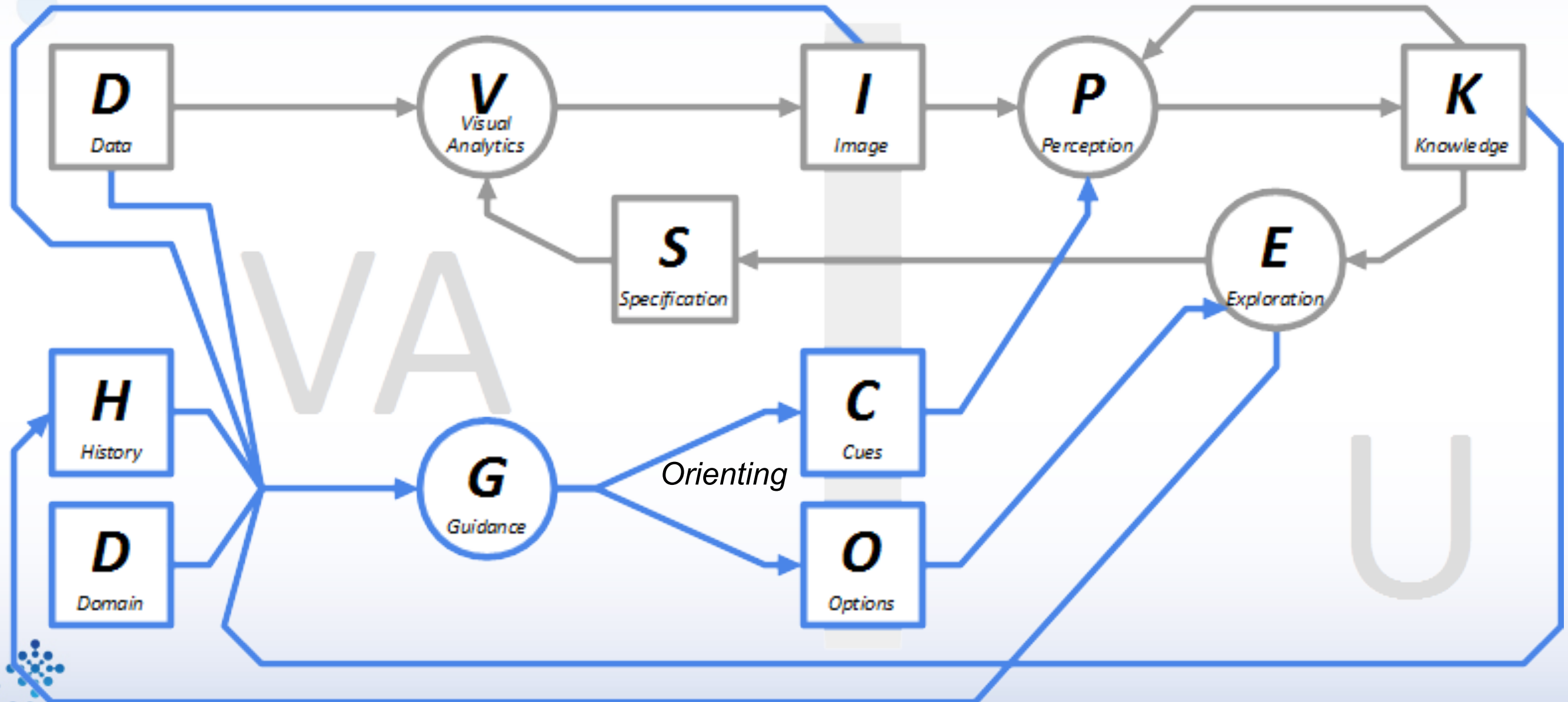

# The Computer-Assisted Process

## The Guidance Degree: Directing – Where should I go?

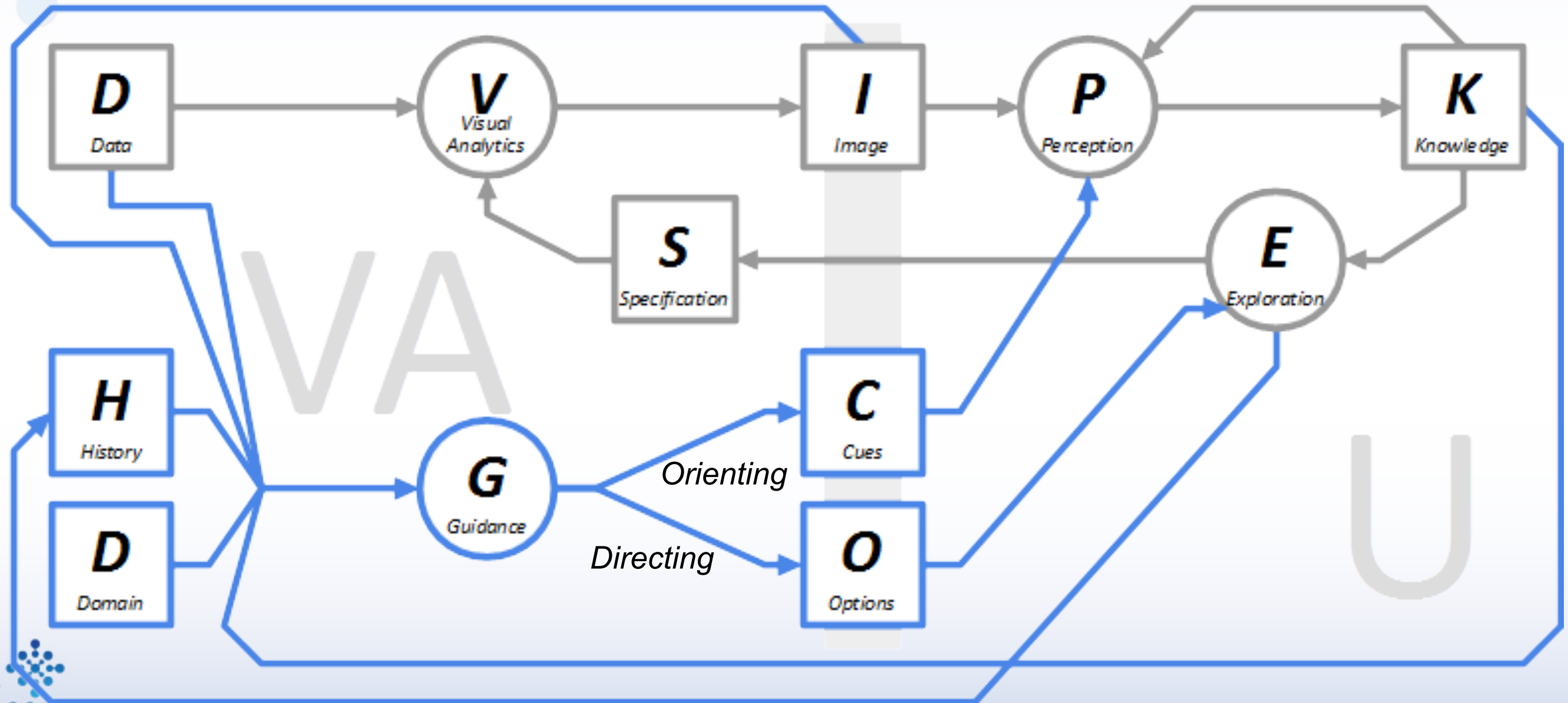

# The Computer-Assisted Process

## The Guidance Degree: Prescribing – Take me to ...!

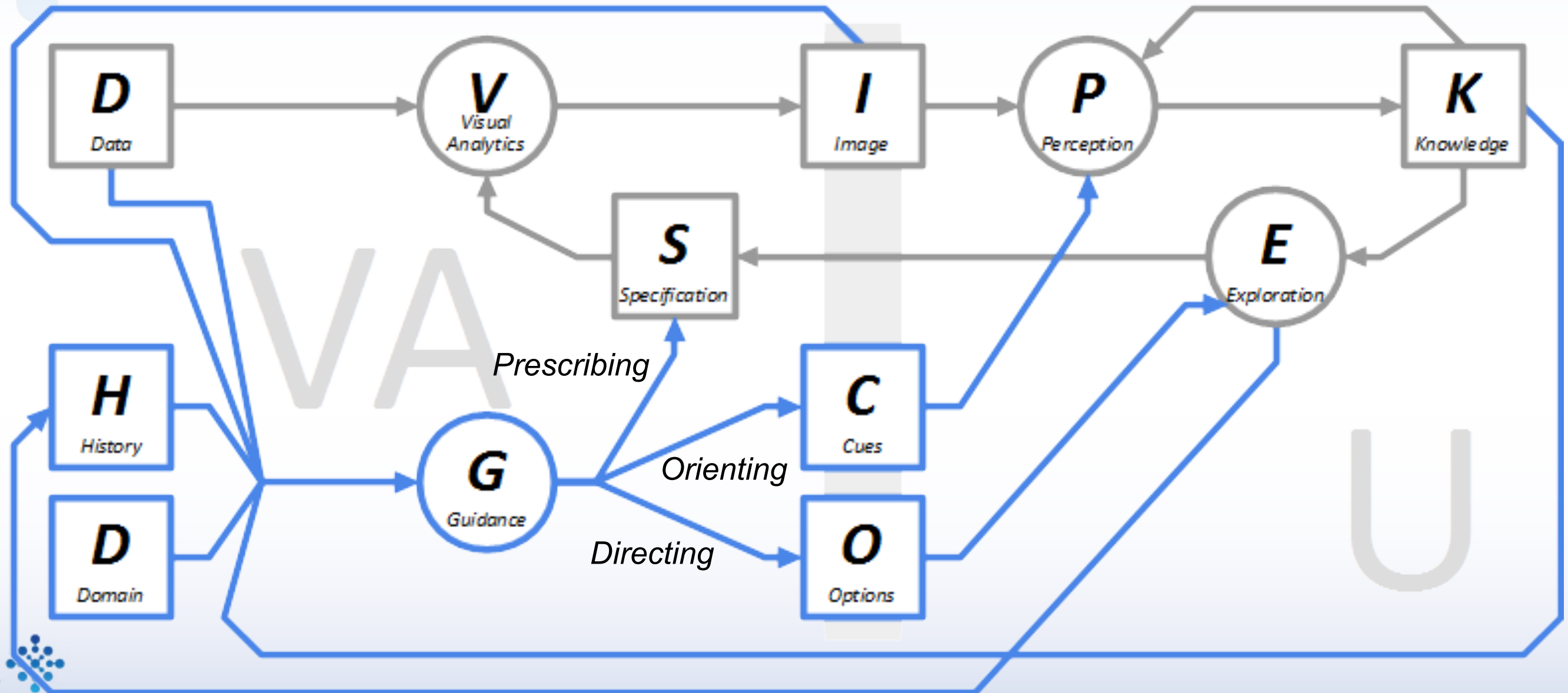



# So this is what Guidance is! Now what?

Our characterization can be used:

- as a framework for capturing guidance requirements
- to match-up guidance methods for user studies
- to couple guidance methods that complement each other
- for characterizing existing guidance methods independent of their respective domains or implementations

# Guidance in literature

## Heterogeneity-based guidance for exploring multiscale data

**Knowledge Gap:** Unknown target/Data.

**Input:** Data

**Output:** Indication of interesting data regions

**Degree:** Orienting

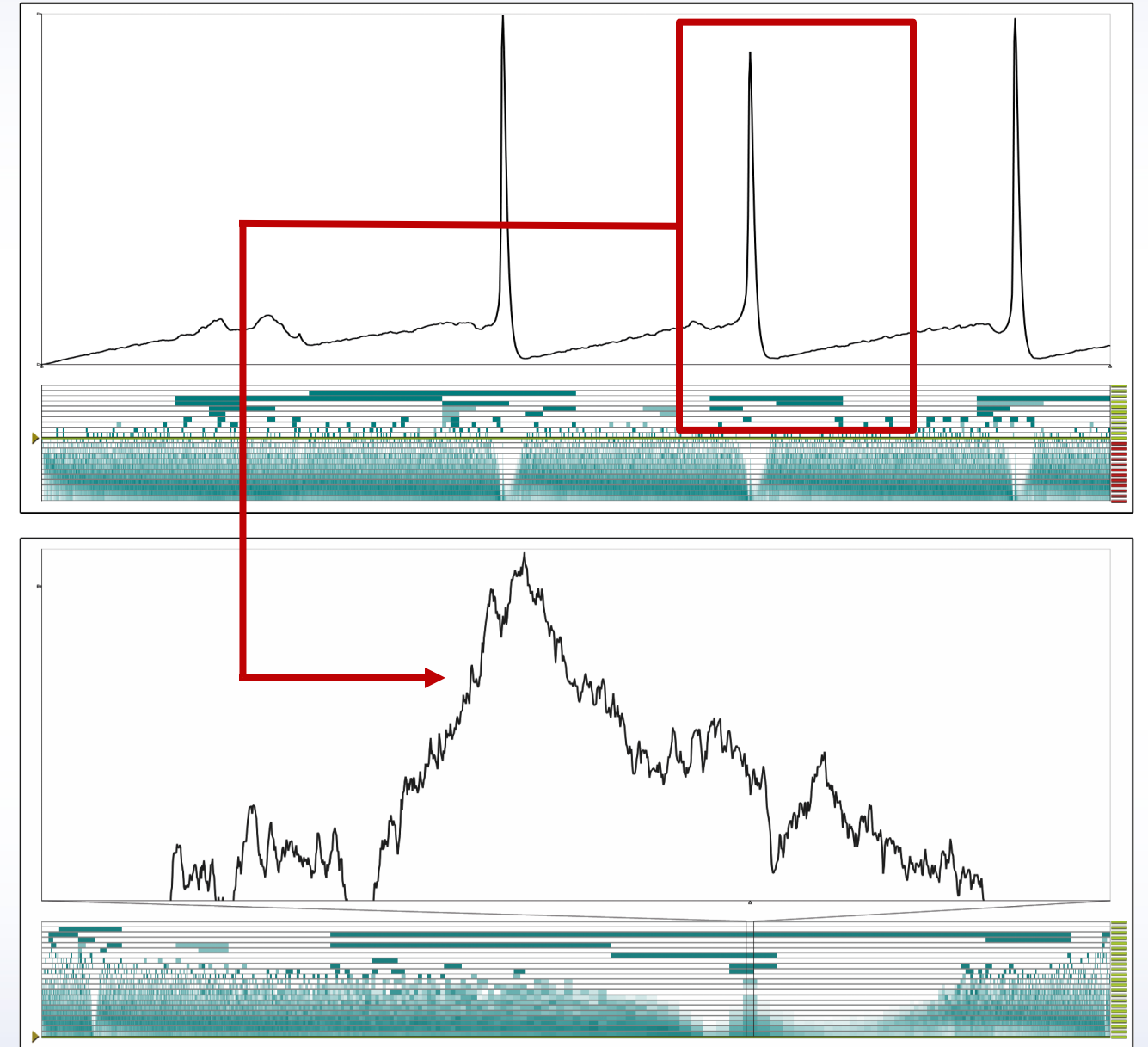

[Luboschik et al. 2012]



# Guidance in literature

## Using Signposts for Navigation in Large Graphs

**Guidance Type:** Unknown path

**Guidance Domain:** Data

**Guidance Input:** Data

**Guidance Output:** Visual Cue

**Guidance Degree:** Orienting

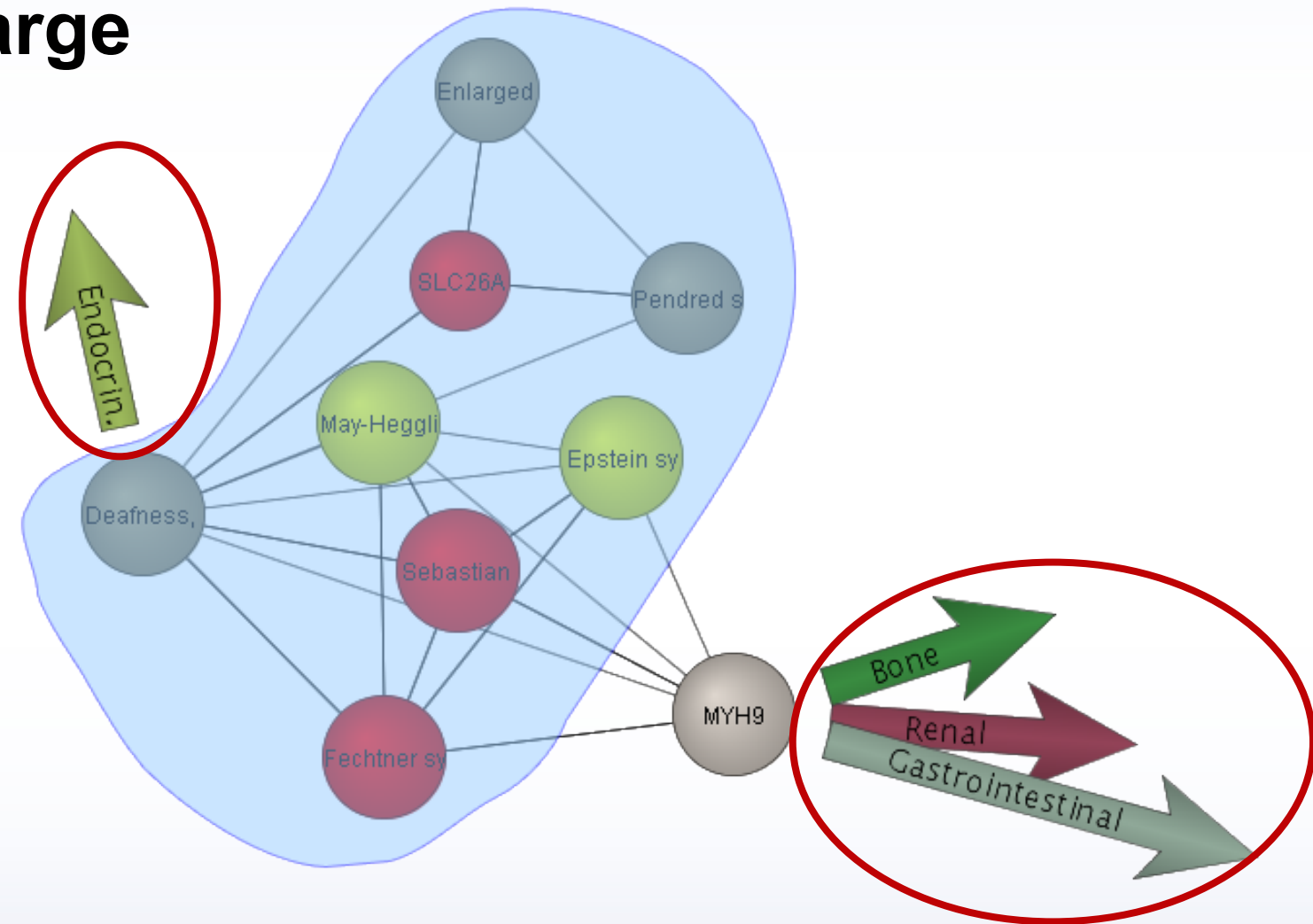

[May et al. 2012]

# Guidance in literature

## Model-Driven Design for the Visual Analysis of Heterogeneous Data

**Knowledge Gap:** Data, Tasks

**Input:** Model/Data/Domain Knowledge

**Output:** tree-shaped meta visualization

**Degree:** Orienting/Directing

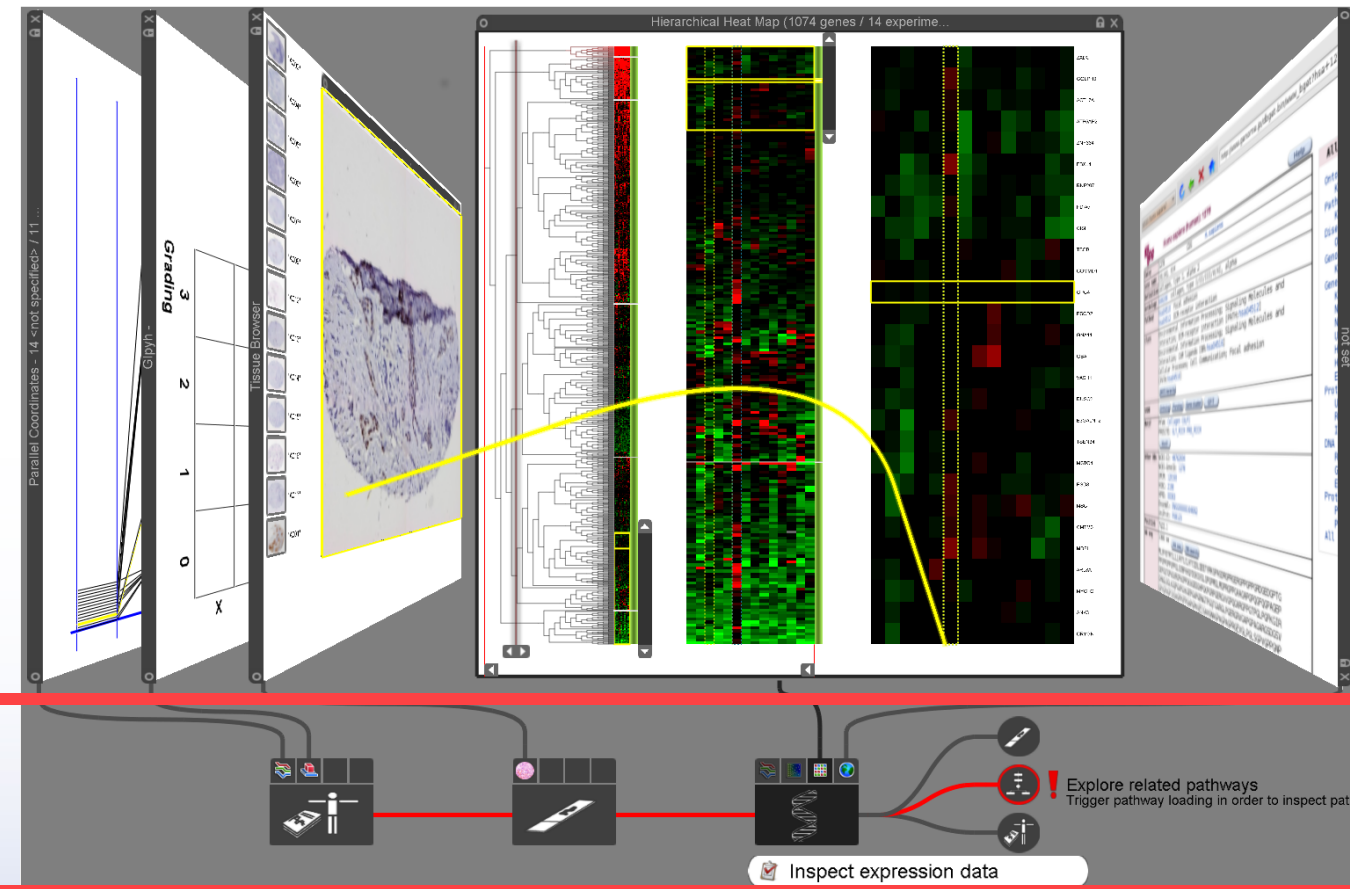
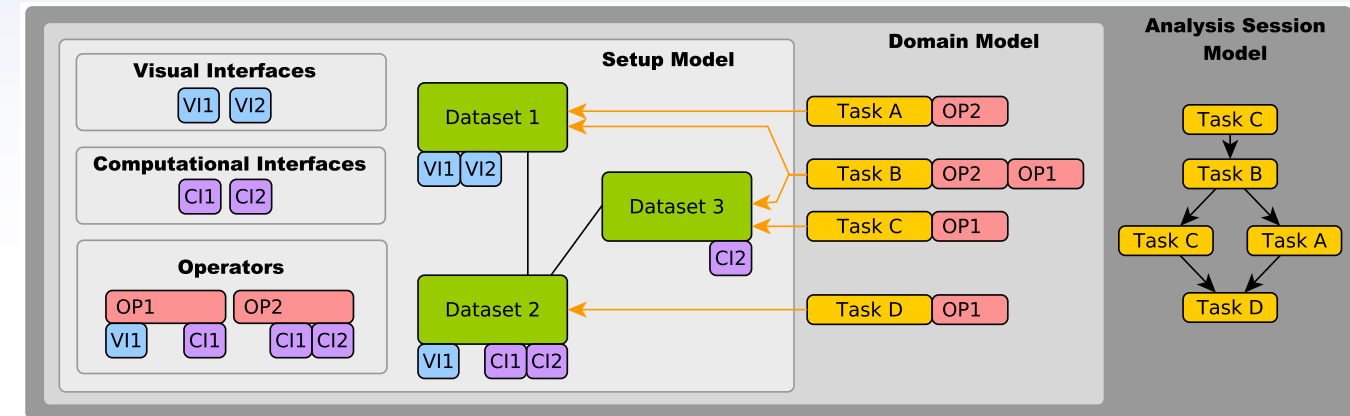



# Main contributions

- A definition of guidance in VA
- A characterization of guidance in VA
- A conceptual model of guidance, including the main aspect of guidance in VA
- A review of guidance approaches



# Future research

## **Refining the model**

How guidance is generated?

How is it possible to evaluate guidance?

## **Guidance and guidelines**

Missing guidelines to apply guidance to the VA process

## **From guidance to mixed initiative visual analytics**

Include users assisting the computer in the guidance equation

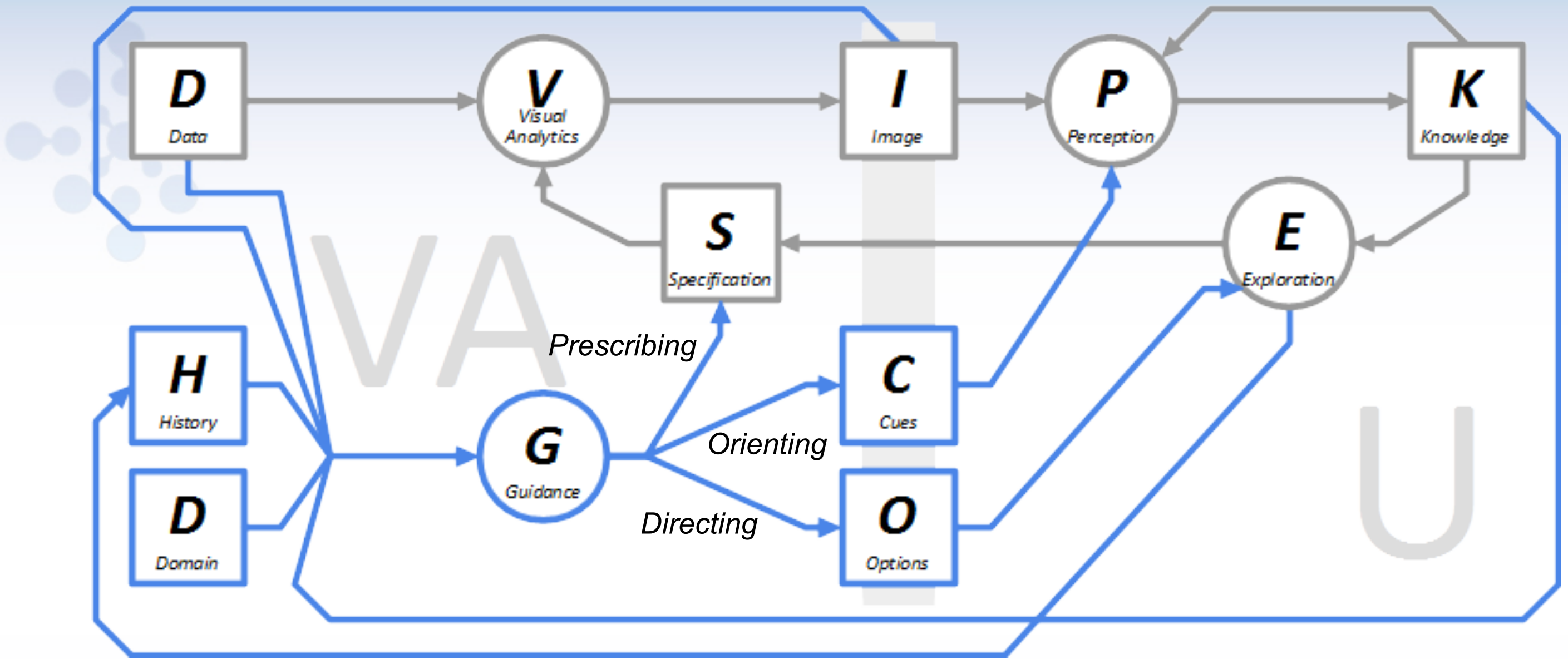

Funding provided by:



Laura Bassi Centre of Expertise  
**Centre for Visual Analytics  
 Science & Technology**

**DAAD**

Deutscher Akademischer Austausch Dienst  
 German Academic Exchange Service

# Guidance Output:

The Answer that fills or bridges the knowledge gap

- **Direct Answer: given in the same domain as the knowledge gap**  
*Example: What to do next?*  
→ use analytic workflow to suggest task
- **Indirect Answer: given in another domain than the knowledge gap**  
*Example: What to do next?*  
→ use interaction logs to show which VA methods other users have used on which data subsets